

2-1

University of Asia Pacific
Department of Civil Engineering
Mid Term Examination, Spring 2024
Program: B. Sc. in Civil Engineering
(Self-Study)

Course Title: Bangladesh Studies: Society and Culture

Time: 01 hour

Credit Hours: 02

Course Code: HSS 211(a)

Full Marks: 20

There are three questions. Answer ANY TWO. (10 x 2=20)

1. a. Name four major theoretical perspectives sociologists use. Mention the key persons. 4
b. Briefly state the differences between the conflict and the functionalist perspectives with relevant examples. 6
2. a. Define socialization. 2
b. Discuss how the agencies of socialization play a role in our lives. 8
3. a. How did Gerhard Lenski define sociocultural evolution? 2
b. How did he relate the evolution of human societies with the innovation of technology? Briefly discuss how Lenski described societies that had changed over the past 3 million years. 8

University of Asia Pacific

Department of Civil Engineering

Mid-Semester Examination Spring-2024

Program: B. Sc. Engineering (Civil) (2nd Year/ 1st Semester)

Self-Study

Course Title: Bangladesh Studies: History Course No. HSS 211(b)

Credit: 2.00

Total Time: 1 Hour

Full Marks: 40

There are **three** questions. Answer any **two including Q-3**. All questions are of equal value. Figures in the right margin indicate marks.

1. Describe the activities of the first important ruler of ancient Bengal. [20] CO1
- OR**
2. Describe the glories of the Pala dynasty. [20] CO1
3. Discuss the economic and political changes under the Muslim rule in the Medieval Bengal. [20] CO2

University of Asia Pacific
Department of Civil Engineering
Mid-Term Examination, Spring 2024
Program: B.Sc. in Civil Engineering

Course Title: Material Science and Environmental Sustainability

Course Code: CE 207

Time: 1 hour

Credit Hour: 3.0

Full Marks: 40

Answer all the questions.

[Assume reasonable data if required]

PART A

1. a) Sketch a Body centered tetragonal unit cell and within that cell indicate the locations of $1 \frac{1}{2} \frac{1}{3}$. [6]
- b) Using **Figure 1** determine the Miller-Bravais indices of the connecting direction from origin O to corner 7. [6]

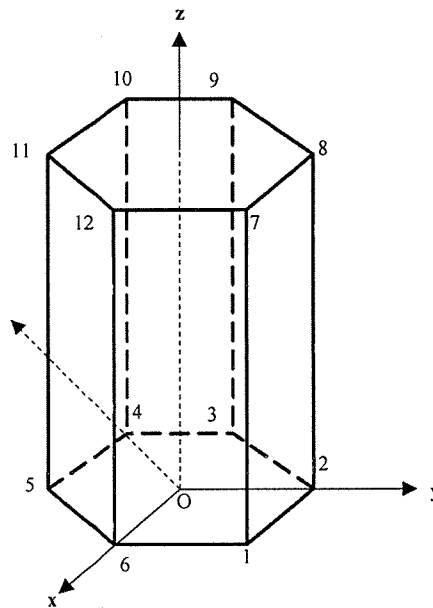

Figure 1

- c) Construct a $(0\ 0\ 2)$ plane within a Face Centered Cubic (FCC) cell and determine the planer density. Given, length of unit cell along x axis = 0.123 nm. [8]
- d) With neat sketch discuss the bonding forces acting among atoms. [4]
- e) Compare ionic, covalent and metallic bonds. [3]

PART B

2. a) On 24 October 2024 the following air quality data have been recorded at a monitoring station in 5 Dhaka: $PM_{2.5} = 450 \mu\text{g}/\text{m}^3$ (24-hr); $O_3 = 420$ ppb (8-hr); $NO_2 = 0.94 \text{ mg}/\text{m}^3$ (Annual). Prepare the AQI index report of the given scenario. [5]
- b) Differentiate between non- renewable and renewable energy. [2]
- c) Identify two potential climate change impacts with examples. [2]
- d) Define Indirect use values and Bequest values and explain how these values apply to Saint Martin's Coral Island. [4]

Required Table

Breakpoints							AQI
O_3 (ppm) 8-hr	O_3 (ppm) 1-hr	$PM_{2.5}$ ($\mu\text{g}/\text{m}^3$) 24-hr	PM_{10} ($\mu\text{g}/\text{m}^3$) 24-hr	CO (ppm) 8-hr	SO_2 (ppm) 24-hr	NO_2 (ppm) Annual	
0.000-0.064	--	0.0-15.4	0-54	0.0-4.4	0.000-0.034	(ii)	0-50
0.065-0.084	--	15.5-40.4	55-154	4.5-9.4	0.035-0.144	(ii)	51-100
0.085-0.104	0.125-0.164	40.5-65.4	155-254	9.5-12.4	0.145-0.224	(ii)	101-150
0.105-0.124	0.165-0.204	65.5-150.4	255-354	12.5-15.4	0.225-0.304	(ii)	151-200
0.125- 0.374	0.205-0.404	150.5-250.4	355-424	15.5-30.4	0.305-0.604	0.65-1.24	201-300
(iii)	0.405-0.504	250.5-350.4	425-504	30.5-40.4	0.605-0.804	1.25-1.64	301-400
(iii)	0.505-0.604	350.5-500.4	505-604	40.5-50.4	0.805-1.004	1.65-2.04	401-500

(ii) NO_2 has no short-term air quality standard and can generate an AQI only above 200.

(iii) 8-hr O_3 values do not define higher AQI values (≥ 301). AQI values of 301 or higher are calculated with 1-hr O_3 concentration.

University of Asia Pacific
Department of Civil Engineering
Mid-term Examination Spring-2024
Program: B.Sc. in Engineering

Course Title: Mathematics-III
Time: 1.00 Hour

Credit Hour: 3.00

Course Code: MTH 201
Full Marks: 60

There are four (4) questions. Answer three (3) questions including Q1 and Q2. Figures given in the right margin indicate the marks of the respective questions.

1. a) Calculate standard deviation calculate mean deviation using empirical relation for the following data: 10

Profit(Lakhs)	0-10	10-20	20-30	30-40	40-50	50-60
No of Companies	8	12	20	30	20	10

- b) Calculate Skewness of the following data: 10

Profit	70-90	90-110	110-130	130-150	150-170
No. of companies	8	11	18	9	4

2. a) In the month of monsoon 60% of the days are rainy and 40% of the days are sunny. It is experienced that meteorology department wrongly predicts 10% of the times in rainy days and 20% of the times on sunny days. Weather forecast indicates a certain day to be sunny. What is the probability that the forecast will be proved wrong? Use Bayes theorem. 10

- b) Find the probability that a family 4 children will be 10
- 1 boy
 - At least 1 boy
 - At least 1 boy and 1 girl
 - 2 boys and 2 girls

3. a) Balance the equation $\text{CO}_2 + \text{H}_2\text{O} \rightarrow \text{C}_6\text{H}_{12}\text{O}_6 + \text{O}_2$ using system of linear equation. 10

- b) Define Hermitian and Skew Hermitian matrix. Find the determinant of the 10

$$\text{matrix} \begin{bmatrix} 4 & -1 & 1 & 6 \\ -1 & 0 & -3 & 3 \\ 1 & 1 & 0 & 14 \\ 6 & 1 & 3 & 2 \end{bmatrix}$$

OR

4. a) The accompanying figure shows a network of one-way streets with traffic 10
flowing in the directions indicated. The flow rates along the streets are
measured as the average number of vehicles per hour.

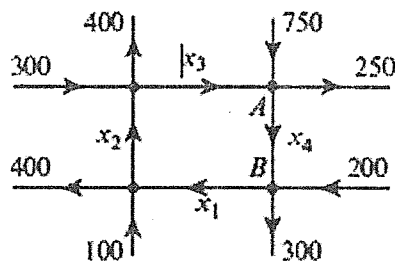

- (a) Set up a linear system whose solution provides the unknown flow rates?
(b) If the flow along the road from A to B must be reduced for
construction, what is the minimum flow that is required to keep traffic
flowing on all roads?

- b) Define Inverse matrix and Identity matrix. Find A^{-1} using Gaussian elimination. 10

$$\text{Where, } A = \begin{bmatrix} -1 & 2 & -3 \\ 2 & 1 & 0 \\ 4 & -2 & 5 \end{bmatrix}$$

University of Asia Pacific
Department of Civil Engineering
Mid-Term Examination, Spring 2024
Program: B. Sc. in Civil Engineering

Course Title: Mechanics of Solids I
 Time: 1-hour

Credit Hours: 3.0

Course Code: CE 211 OBE
 Full Marks: 40 (10 × 4)

ANSWER ALL THE QUESTIONS

- Use Singularity Function to derive the shear force and bending moment equations of the beam *ABCD* loaded as shown in *Fig.1*. Also calculate bending moment at C (M_C) and shear force at right of B (V_{BR}).

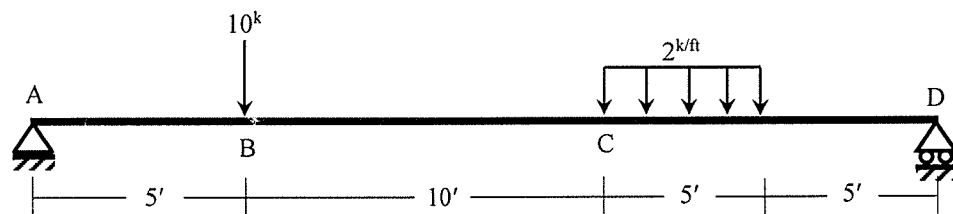

Fig.1

- Use integration method to draw the shear force diagram and bending moment diagram of the beam *ABCD* loaded as shown in *Fig.2*.

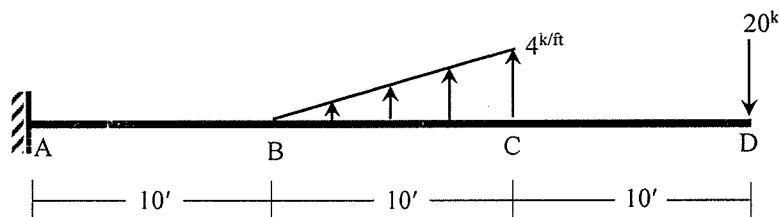

Fig.2

- Draw the axial force, shear force and bending moment diagram for the frame *ABCDE* loaded as shown in *Fig.3*.

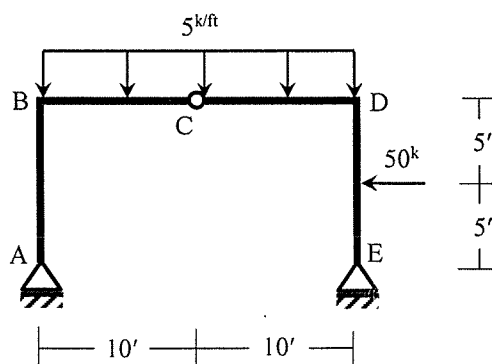

Fig.3

4. (i) Calculate the maximum allowable value of P for the axially loaded member abc shown in Fig.4.
(ii) For the force P calculated in (i), determine the lengths of 12 mm welds to connect the members ab and bc at joint b
[Given: Allowable stress in shear = 200 MPa, tension = 250 MPa, compression = 180 MPa].

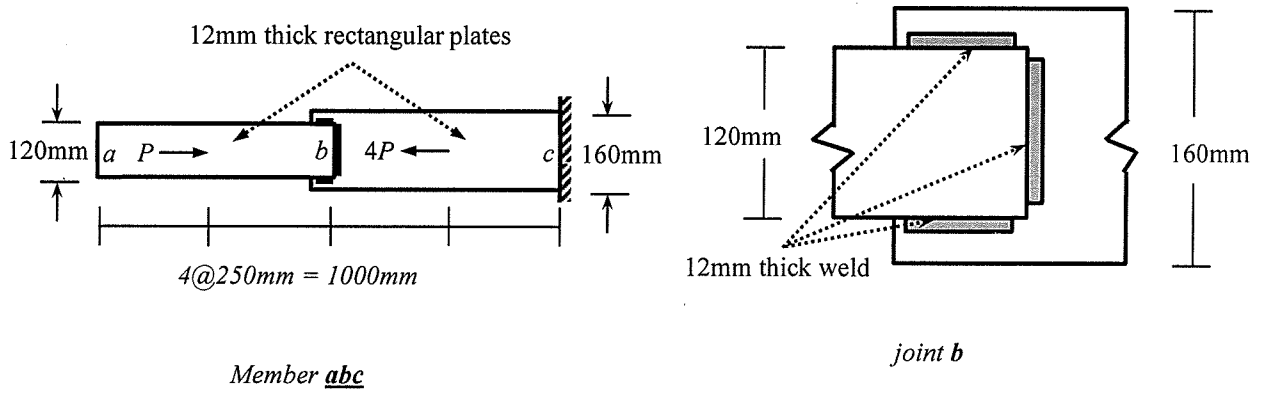

Fig.4

University of Asia Pacific
Department of Civil Engineering
Midterm Examination, Spring 2024
Program: B.Sc. Engineering (Civil)

Course Title: Principles of Accounting
Time: 1 hour

Credit Hour: 2

Course Code: ACN 201
Full Marks: 20

There are **Three Questions**. Answer any **Two including Question 1**. All questions are of equal value. Figures in the right margin indicate marks. Please return the question with the answer script.

1. a. Define “**Accounting**” in your own words. [3]
- b. For each of the following scenarios, determine whether it represents an *economic transaction or not for SRF Company*. Provide a brief explanation for your answer. [7]
 1. SRF Company purchases raw materials from a supplier for BDT 50,000.
 2. The Company gifted unused machinery to a local technical school free of cost.
 3. The Company hires employees at a total cost of BDT 20,000.
 4. The CEO gives a car to his only child by BDT 50,000.
 5. The Company receives a loan of BDT 100,000 from a bank to expand its operations.
 6. The Company sends out free samples of its products to potential customers BDT 2,00,00.
 7. The CFO invests in new technology and purchases advanced manufacturing equipment for his daughter’s company BDT 1,00,000.
2. a. Discuss the basic activities of accounting. [3]
- b. **Bryan Car Repair Company** entered into the following transactions in March 2024. Prepare a “**Tabular analysis**” for the following *transactions*: [7]
 1. Rick invested BDT 10000 cash in “Bryan” car repair company.
 2. The company paid for its commercial space of BDT 2500 to cover the month of March.
 3. Bryan purchased equipment on credit. BDT 6000 is due to be paid at the end of the month.
 4. Performed car repair work for the first two weeks of March and yet to receive BDT 7000.
 5. The owner withdrew cash BDT 600 for personal use.
 6. Performed services worth BDT 8,000: BDT 3,000 cash is received from customers, and the balance is billed to customers on account.
 7. Paid BDT 6000- the due amount for the purchase of the equipment.
 8. Borrowed BDT 5000 cash from the bank signing a note.
 9. Incurred utility expenses for a month on account BDT 400.
 10. Received BDT 6000 in cash for the services performed in the past.

OR

3. At the beginning of February 2024, **Shafayat Corporation** had the following account balances:

- Cash: BDT 60,000
- Accounts Receivable BDT 5,000
- Equipment: BDT 60,000
- Accounts Payable: BDT 15,000
- Bank Loan: BDT 30,000
- Owner's Equity: BDT 80,000

During the Month, the Company:

Feb 1: Purchased equipment for BDT 20,000 in cash.

Feb 12: Purchased goods BDT 25,000 on credit from Motasim.

Feb 13: Sold goods on cash for BDT 45,000.

Feb 20: Paid BDT 1,000 for advertising expenses

Feb 28: Paid salaries to employees BDT 6,000.

- a. Using the accounting equation (*Assets = Liabilities + Owner's Equity*), show how each transaction impacts the Company. [07]
- b. Prepare the "**Journal entries**" from the transactions of February 2024. [03]

University of Asia Pacific
Department of Civil Engineering
Mid-Term Examination Spring 2024
Program: B.Sc. Engineering (Civil)

Course Title: Engineering Materials
 Time: 1 hour

Credit Hour: 3.00

Course Code: CE 201
 Full Marks: 60

Answer all four questions

Part A

1. a) List the chemical names and percentage composition of the four mineral constituents of OPC. Interpret and explain the following graph. [10+5+3]

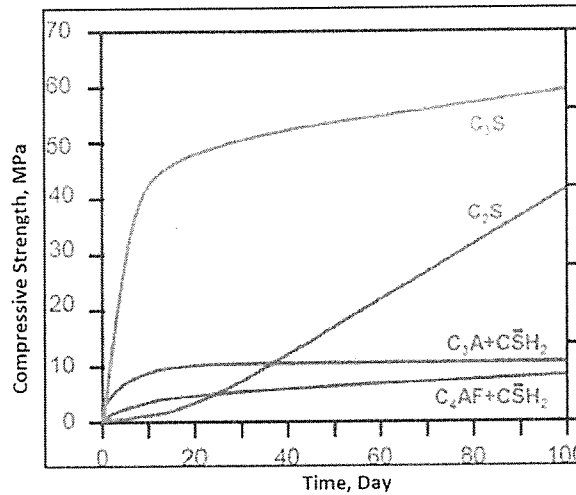

b) Write in tabular form the ASTM designations, names and compositions of blended cement.

c) Identify the composition of the cement with marking 'CEM II /A-P'.

2. a) The following data is obtained from sieve analysis of a fine aggregate sample. Draw the gradation curve on the semi-log graph paper provided below. [9+3]

Sieve No.	Sieve opening (mm)	Material retained (gm)
#4	4.75	4.1
#8	2.36	13.2
#16	1.18	401.0
#30	0.60	195.3
#50	0.30	93.5
#100	0.15	30.0
#200	0.075	11.6
Pan	-	1.3

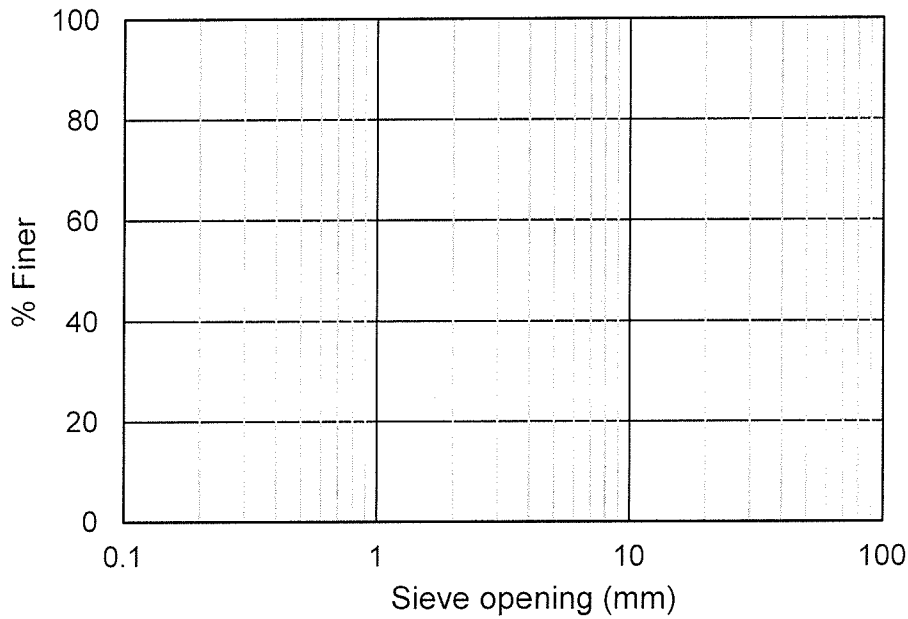

b) Determine the mean diameter and effective size of the aggregate from the gradation curve.

Part B

3. a) Draw the plan of a typical circular Hoffman Kiln showing the chambers used for different functions. Also write which doors should remain closed and which should remain open during operation. [5+5]

b) A brick sample of 1.254 kg oven dry weight is tested for determination of unit weight of brick. If the amount of water displaced by wax coated brick is 1.115 kg, calculate the unit weight of the brick. Note that about 265 gm is used to make wax coating around the brick sample. Assume specific gravity of wax is 0.865 and density of water = 1 gm/cc.

Find the unit weight of the brick and comment whether the brick meets minimum specifications.

4. a) For the loading history shown in the figure, draw the strain response of a **plastic** material and state the characteristics of it. Consider equal time interval. [12+8]

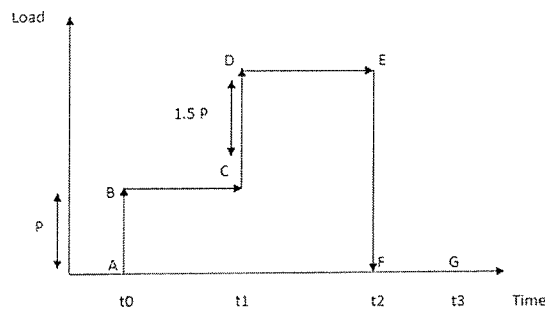

b) Draw stress-strain curve for concrete and write down the characteristics of it. Discuss how it is different from a Mild Steel's stress-strain curve.

University of Asia Pacific
Department of Civil Engineering
Mid-Term Examination, Spring 2024
Program: B.Sc. in Civil Engineering

Course Title: Basic Electrical Engineering
Time: 1 hour

Credit Hour: 3.0

Course Code: ECE (CE) 201
Full Marks: 60

There are four Questions. Answer any **three** of them. Part marks are shown in the margins.

1. Compute the power of ' R_2 ' in figure 1.

[20]

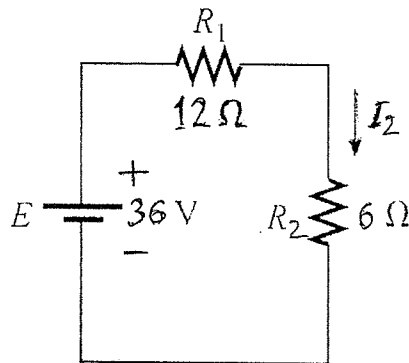

Figure: 1

2. Compute the value of current ' I_2 ' in figure 2?

[20]

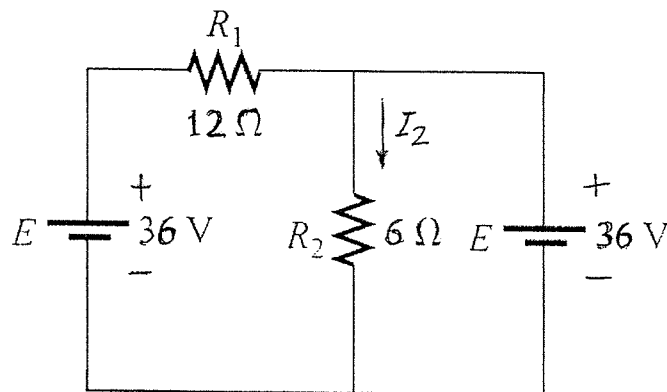

Figure: 2

3. What is the current of 1-ohm resistor?

[20]

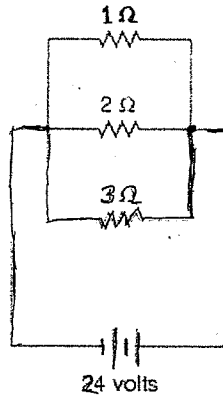

Figure 3

4. Calculate the power delivered by the source in the following circuit.

[20]

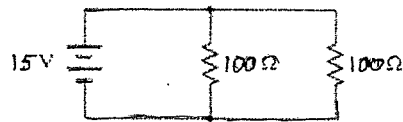

Figure 4